

# LOUVERS

LIMITLESS AS YOUR IMAGINATION

POWERED BY | **ALSTONE**

EXTERIOR & INTERIOR CLADDING

**THE LEGACY OF  
18+ YEARS OF  
DELIVERING OVER  
500+ MILLION Sq. Ft. OF ACPs.**

WELCOME TO

**ALSTONE<sup>®</sup>**

— भरोसे का प्रतीक —

With 18+ years of remarkable consistency, reliability and quality under our belt, Alstone is the natural choice for those who want to make an architectural statement that stands the test of time. The go-to choice for architects, builders and industry professionals, Alstone's extensive design range and unceasing product development ensure all your requirements are met.

Our use of the finest raw materials, high production standards and superior technology is just a small part of our commitment to excellence, and makes us a leading manufacturer of High Pressure Laminate (HPL) & Aluminium Composite Panel (ACP) in India. And now, we are offering even more to make your architectural vision come true.

Introducing our exclusive range of Louvers (Exterior and Interior Cladding Solutions) for premium buildings. Our Louvers have been designed to be nothing short of exquisite, for those who want to be surrounded by architectural elegance. Made to fit your taste, this range is the perfect way to add a personal touch and sprinkle of sophistication to your home or office.

---

***Alstone ACP Products are certified by Thomas Bell-Wright International Lab and trusted by leading PSUs and corporates like LIC, GAIL, Indian Oil, Nayara Energy, AAI, CPWD, DMRC, NBCC, NTPC and many more.***

**ABOUT US**

**LOUVERS**  
LIMITLESS AS YOUR IMAGINATION

POWERED BY | **ALSTONE®**



## WHY LOUVERS

-  EASY INSTALLATION
-  READY TO USE
-  WATER & TERMITE PROOF
-  100% MAINTENANCE FREE
-  WIDE RANGE OF COLOURS
-  IDEAL FOR RESIDENTIAL & COMMERCIAL BUILDINGS





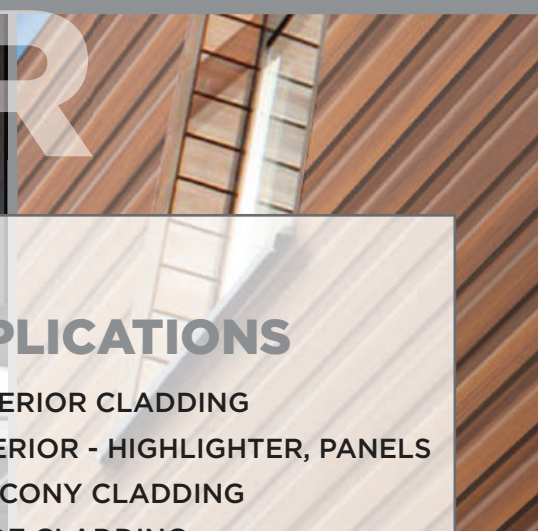
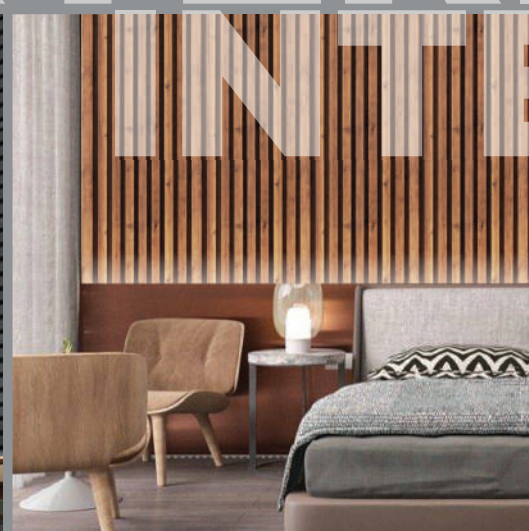

# EXTERIOR INTERIOR

## APPLICATIONS

- EXTERIOR CLADDING
- INTERIOR - HIGHLIGHTER, PANELS
- BALCONY CLADDING
- ROOF CLADDING
- CANOPY
- GATE PANELING
- FENCE & RAILING



EXTERIOR CLADDING

**LOUVERS**  
LIMITLESS AS YOUR IMAGINATION

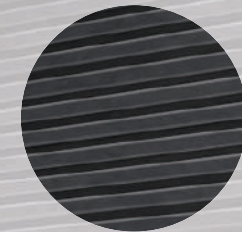

A cool, stormy  
**ARMANI GREY**  
mottled with whispers  
of slate, for panelling  
that inspires awe.





Deep hues of taupe  
weave together to give  
a sleek, urbane

**WENGE**  
look..





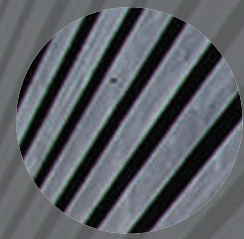

Bands of deep  
**SHADOW GREY**  
juxtapose with charcoal  
to give a modern,  
polished finish.

FENCE & RAILINGS

**LOUVERS**  
LIMITLESS AS YOUR IMAGINATION





Ribbons of chocolate brown mesh with shades of **DARK TEAK** for cladding that exudes elegance.

ROOF CLADDING

**LOUVERS**  
LIMITLESS AS YOUR IMAGINATION





## OXFORD CHERRY

Vivid cherry red,  
speckled with mahogany  
sheen for walls that  
demand attention.

HIGHLIGHTER,  
WALL PANEL

**LOWERS**  
LIMITLESS AS YOUR IMAGINATION



INTERIOR

**LOUVERS**  
LIMITLESS AS YOUR IMAGINATION

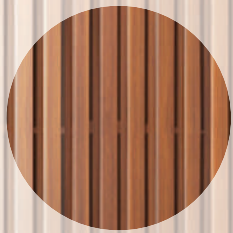

## **ROYAL TEAK**

is an amalgamation of rich, subtle shades of almond that radiate warmth.







## **NOVACENTOPINE**

For a charmingly rustic  
yet sophisticated finish  
that captivates

**INTERIOR**

**LOUVERS**  
LIMITLESS AS YOUR IMAGINATION



INTERIOR

**LOUVERS**  
LIMITLESS AS YOUR IMAGINATION



Blades of raven black  
and muted silver,

**BLACK SILVER**

gives you that stylish  
contemporary look.



INTERIOR

**LOUVERS**  
LIMITLESS AS YOUR IMAGINATION

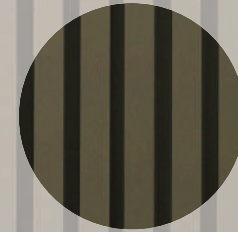

## **COFFEE SILVER**

Distinct bars of coffee with a hint of silver in harmony to give an elegant chic finish.





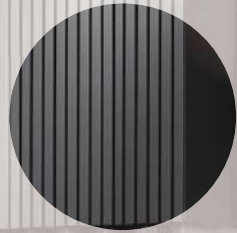

## **DARK GREY**

A true balance of mystery, sophistication & timelessness, this hue of grey adds a modern touch to your walls.





## PURE WHITE

A contemporary classic, for those who like simplicity that makes a statement.





INTERIOR

**LOWERS**  
LIMITLESS AS YOUR IMAGINATION

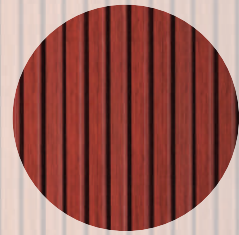

## ROSEWOOD

This deep rosy brown shade is softly streaked with shadows, adding mystical subtlety to your walls.





**NYANA TEAK**

This shade is a harmony of inviting caramel flecked with hints of tawny brown, adding charming depth to your exterior.





## **TINEO**

The synergy of a deep brown with the warmth of almond make for an enchanting visual for your eyes.



INTERIOR

**LOUVERS**  
LIMITLESS AS YOUR IMAGINATION



## TIGER WOOD

With its remarkable grain, and variations ranging from golden tan to a deep russet brown, this shade is made to draw all attention.



AL-1001 PURE WHITE



AL-1002 COFFEE SILVER



AL-1003 DARK GREY



**LOUVERS**  
LIMITLESS AS YOUR IMAGINATION



AL-1004 BLACK SILVER



AL-1101 NOVACENTOPINE



AL-1102 DARK TEAK



**LOUVERS**  
LIMITLESS AS YOUR IMAGINATION



AL-1103 ROYAL TEAK



AL-1104 NYANA TEAK

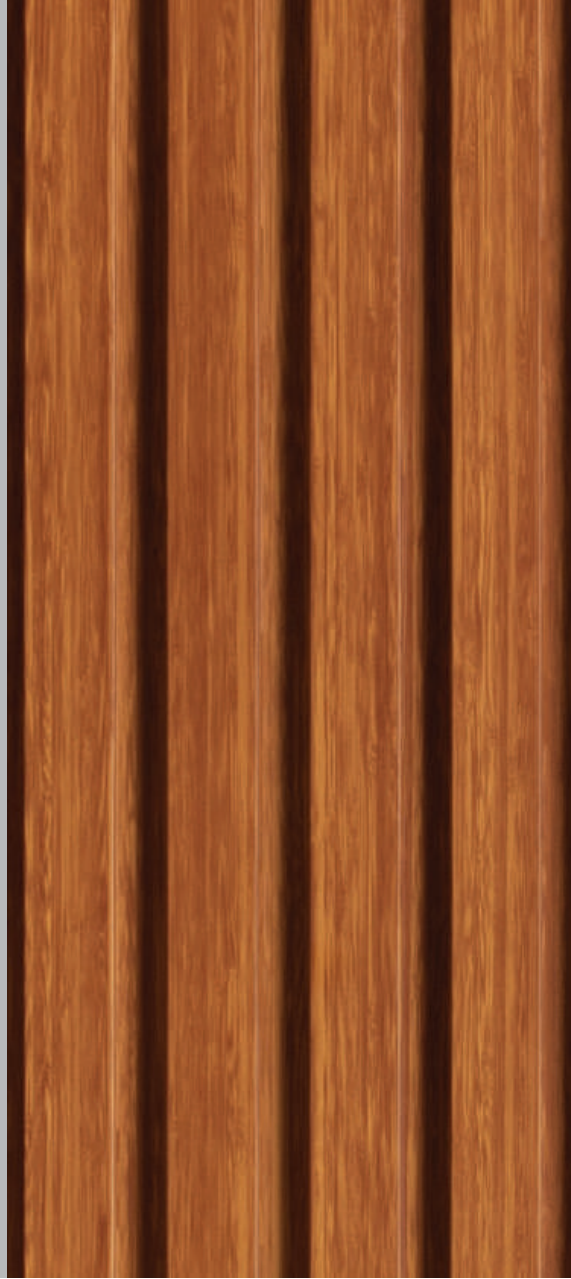

AL-1105 WENGE



**LOUVERS**  
LIMITLESS AS YOUR IMAGINATION



AL-1106 TINEO



AL-1107 TIGER WOOD



AL-1108 OXFORD CHERRY





AL-1109 ROSEWOOD



AL-1110 ARMANI GREY



AL-1111 SHADOW GREY



**LOUVERS**  
LIMITLESS AS YOUR IMAGINATION



**Series: 3200**

625mm(W) x 2440mm(H),  
Panel Thickness: 30mm  
Tolerance:  $\pm 10$ mm

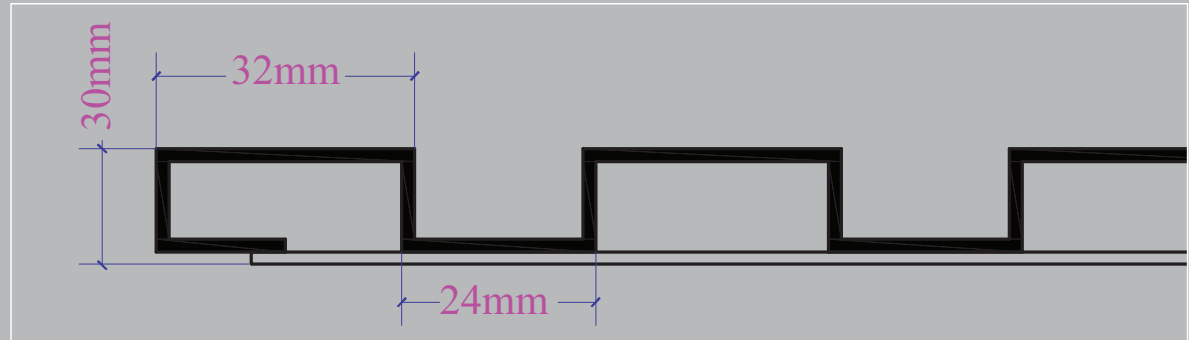

**Series: 5500**

770mm(W) x 2440mm(H),  
Panel Thickness: 30mm  
Tolerance:  $\pm 10$ mm

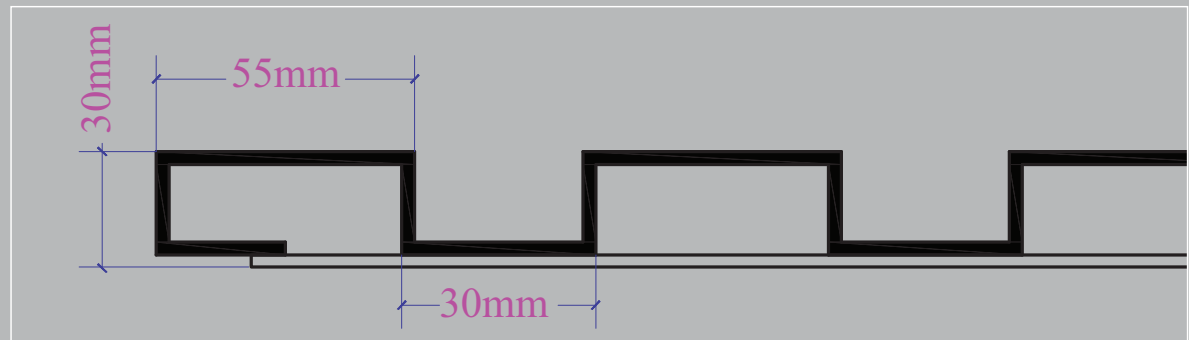

*\*Customised length is also available (up to 3660mm).*

*\*\*Actual colours may vary from the pictures shown in the brochure.*



# ALSTONE®

---

## Corporate Office :

### Alstone Manufacturing Private Limited

15th Floor, Vijaya Building, Barakhamba Road, Connaught Place, New Delhi-110001

E info@alstoneindia.com | W www.alstoneindia.com | Toll Free No. 18001233123

Plant : 1393, Langha Road, Industrial Area, Dehradun, Uttarakhand.

## Branch Offices :

Delhi | Noida | Lucknow | Jaipur | Indore | Raipur | Ahmedabad | Mumbai

Pune | Patna | Ranchi | Kolkata | Bhubaneswar | Bangalore | Kochi | Hyderabad



f in @ /alstonepanels

OUR GROUP COMPANY  
**emerge**  
glass

ALUMINIUM HONEYCOMB PANEL

FIRE RATED COMPOSITE PANEL

HIGH PRESSURE LAMINATE (HPL)