



WALLS

Feature Wood Coverings

Hollmium Collection

Now available in Engineered Wood

TURAKHIA



TURAKHIA
DECOR



WALLS

Feature Wood Coverings

INTRODUCTION

Turakhia Décor introduces TD Walls, an unprecedented range of engineered wood wall coverings in distinctive patterns and vibrant colors. It enables you to experience wood in different moods and different tastes. For the first time a pre-oiled wood panel product is offered to the Indian market to reduce post installation hassles.

Hollmium Collection 2023



WALLS

Feature Wood Coverings

ROSE SERIES



Technical Details:-

Wood Veneer Specie	: INDIAN ACACIA
Wear Layer	: 0.5 mm
HDF Core	: HDHMR Grade
Wood Pieces Per Panel	: 216
Weight Per Panel	: 2.5 K.G.
Internal Groove Size	: 1.5 mm
Out-to-Out	: 1274.06 MM X 661.56 MM
In-to-In	: 1223.72 MM X 611.10 MM
Coverage in Sq. Ft	: 8 Sq. Ft. Per Panel
Thickness of Engineered Composite	: 4 mm
Backer	: Polyester Fabric
Finish	: Pre- Oiled

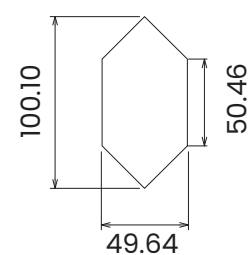
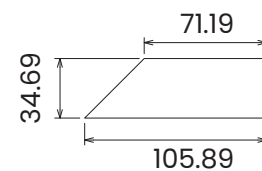
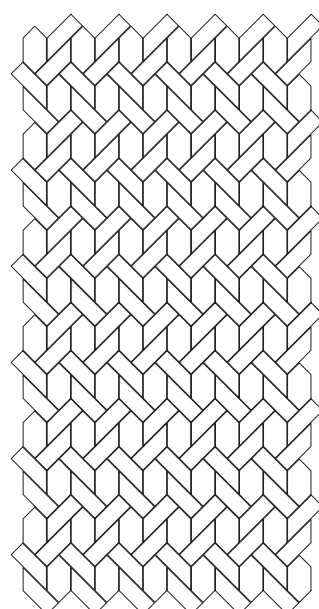

Scan

Hollmium Collection 2023



WALLS

Feature Wood Coverings

ROSE SERIES



RSE 6.91



RSE 6.92

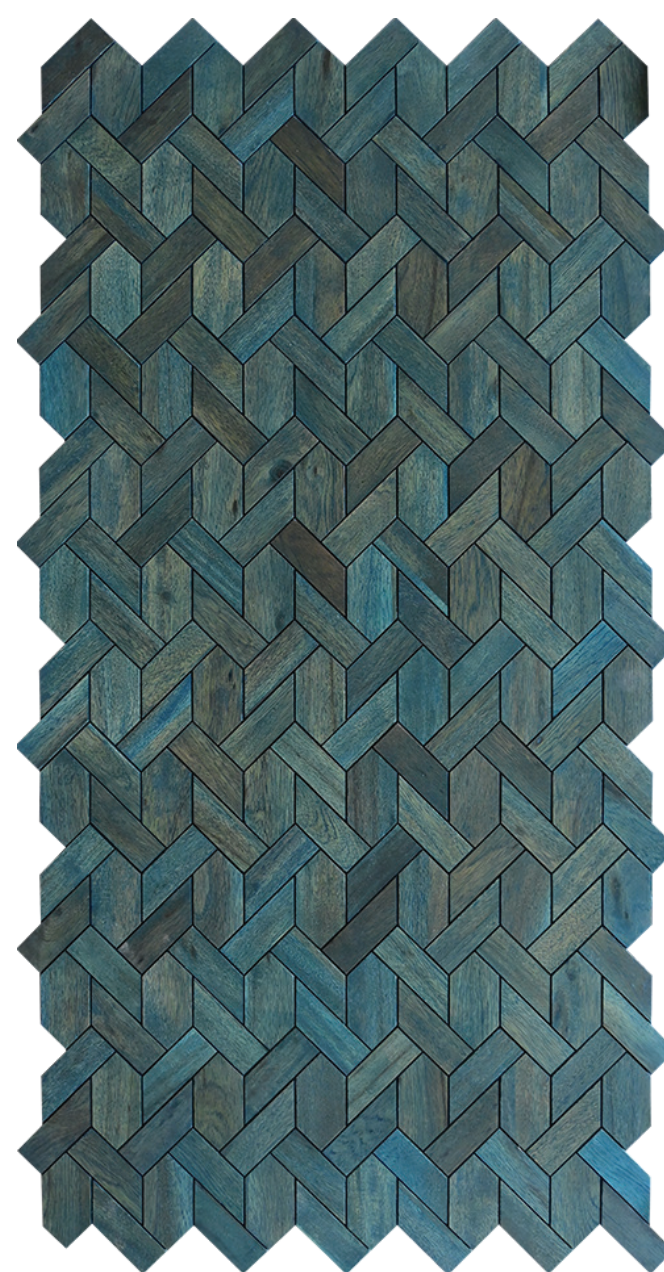

RSE 6.93

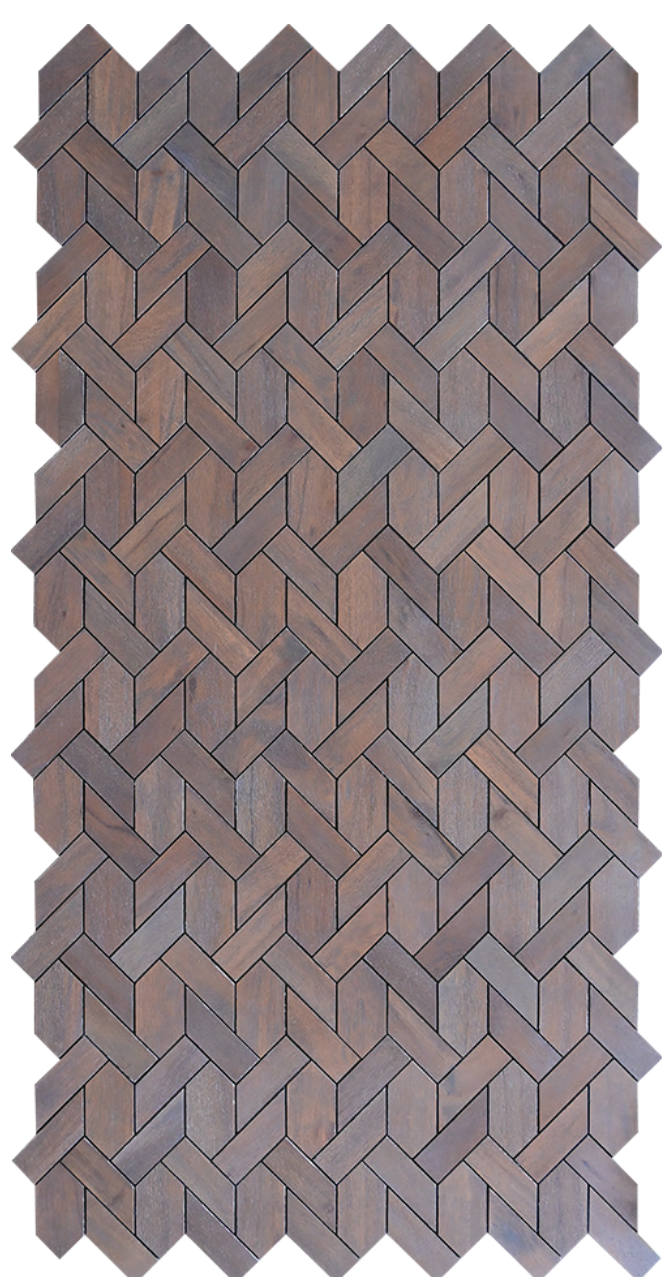

RSE 6.94



RSE 6.95



RSE 6.96

Hollmium Collection 2023



WALLS

Feature Wood Coverings

LILY SERIES



Technical Details:-

Wood Veneer Specie	: INDIAN ACACIA
Wear Layer	: 0.5 mm
HDF Core	: HDHMR Grade
Wood Pieces Per Panel	: 192
Weight Per Panel	: 2.5 K.G.
Internal Groove Size	: 1.5 mm
Out-to-Out	: 1233.17 MM X 654.66 MM
In-to-In	: 1211.29 MM X 616.07 MM
Coverage in Sq. Ft	: 8 Sq. Ft. Per Panel
Thickness of Engineered Composite	: 4 mm
Backer	: Polyester Fabric
Finish	: Pre- Oiled

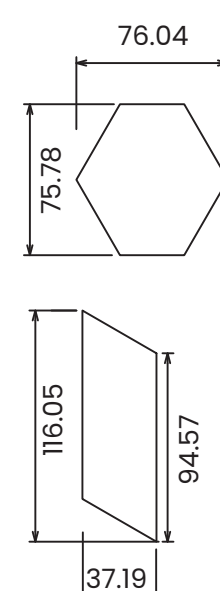
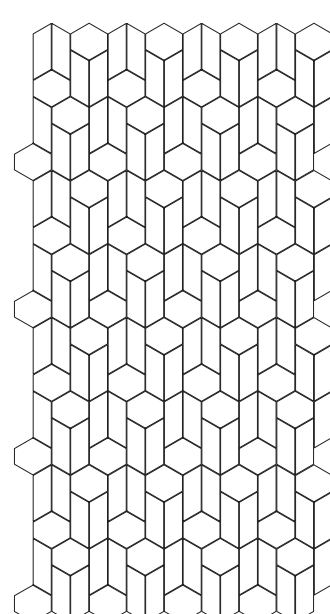

Scan

Hollmium Collection 2023



WALLS

Feature Wood Coverings

LILY SERIES

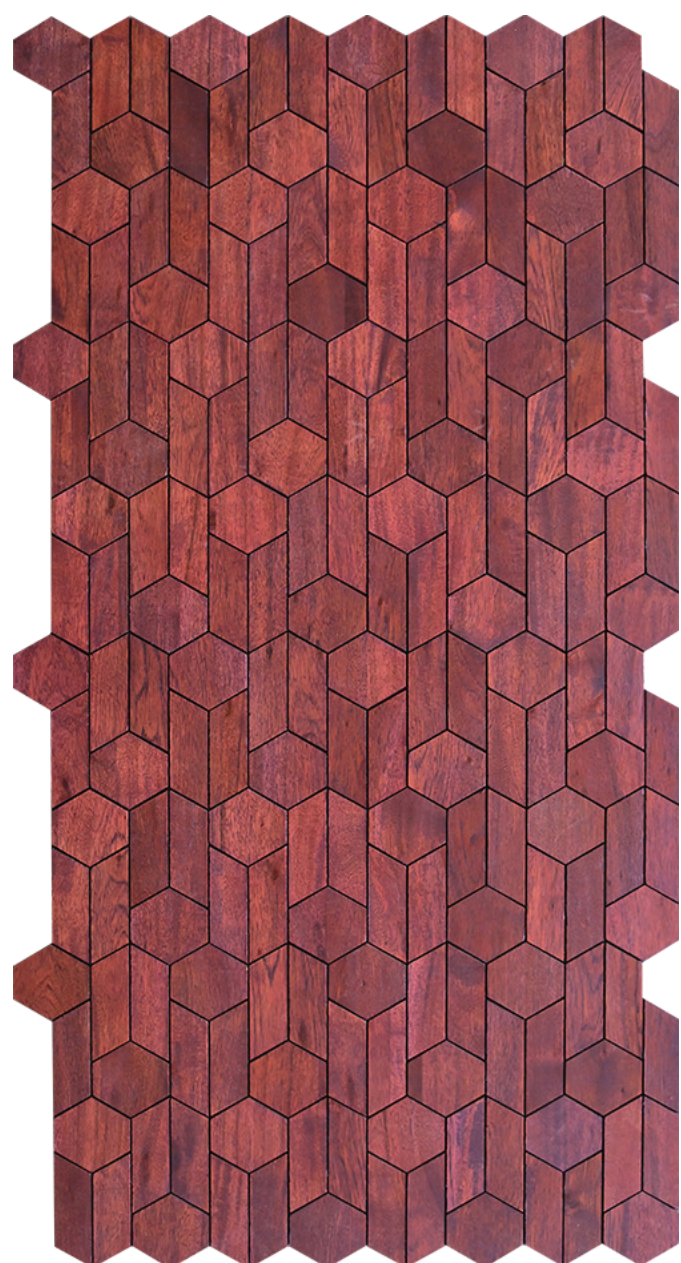

LLY 6.91

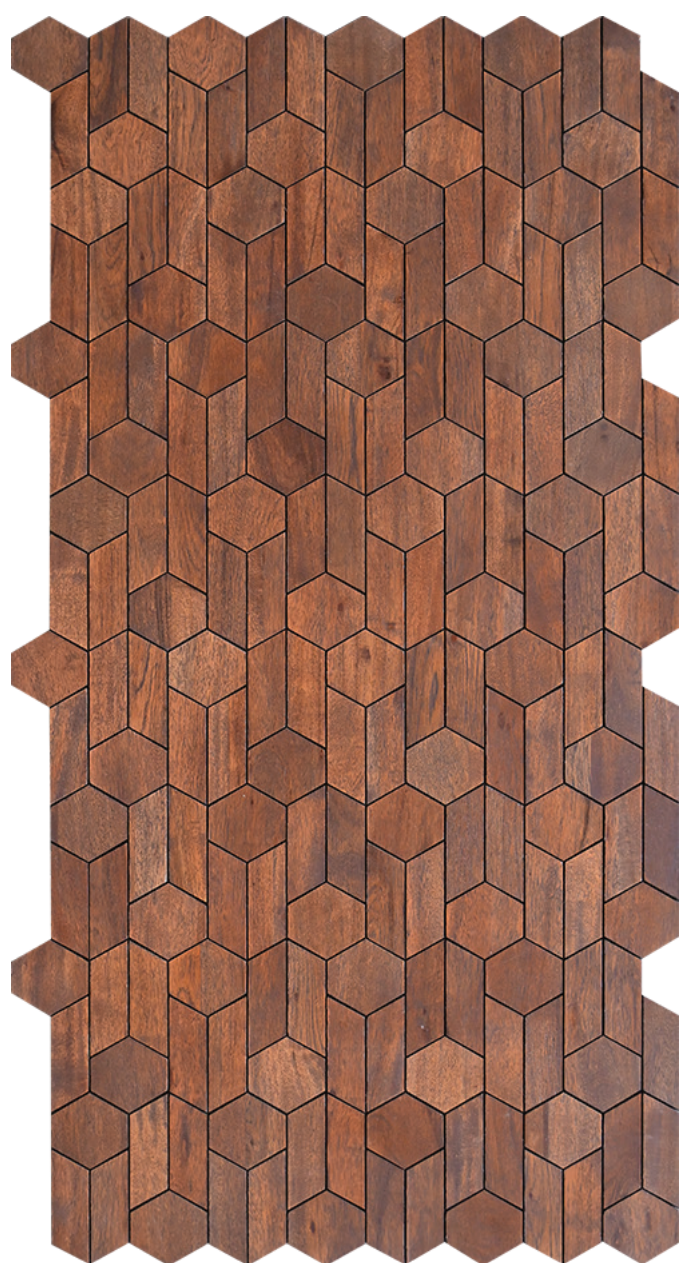

LLY 6.92

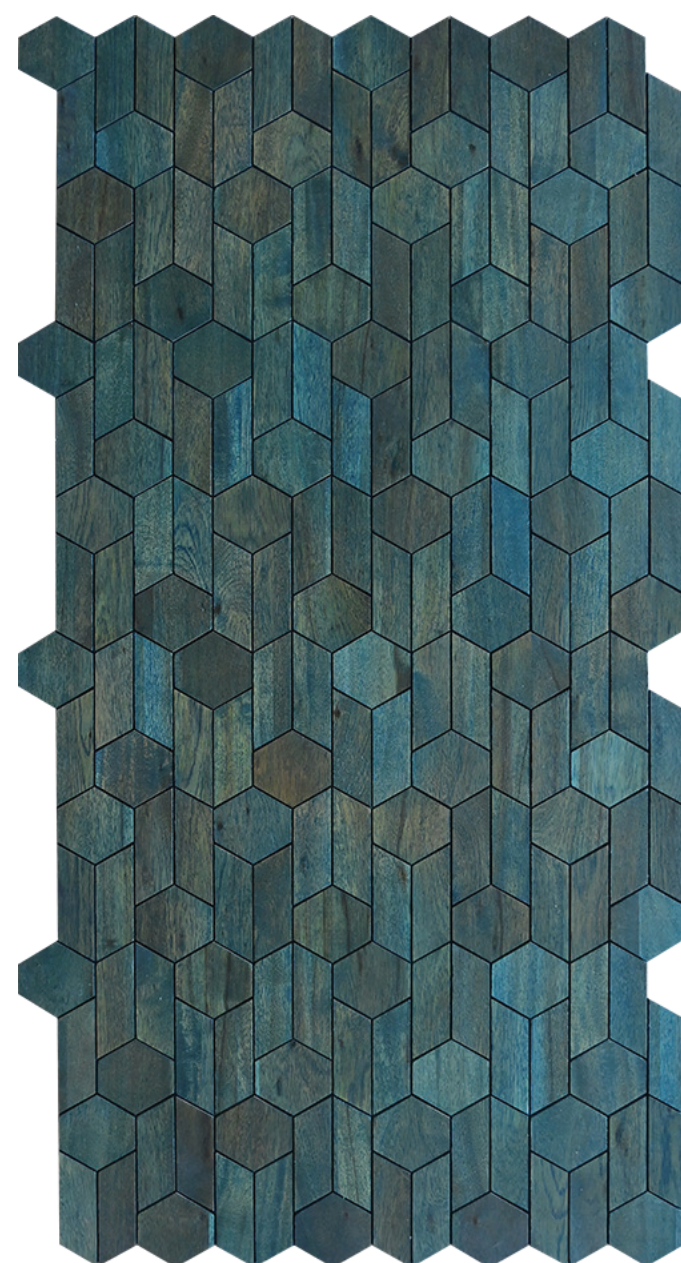

LLY 6.93

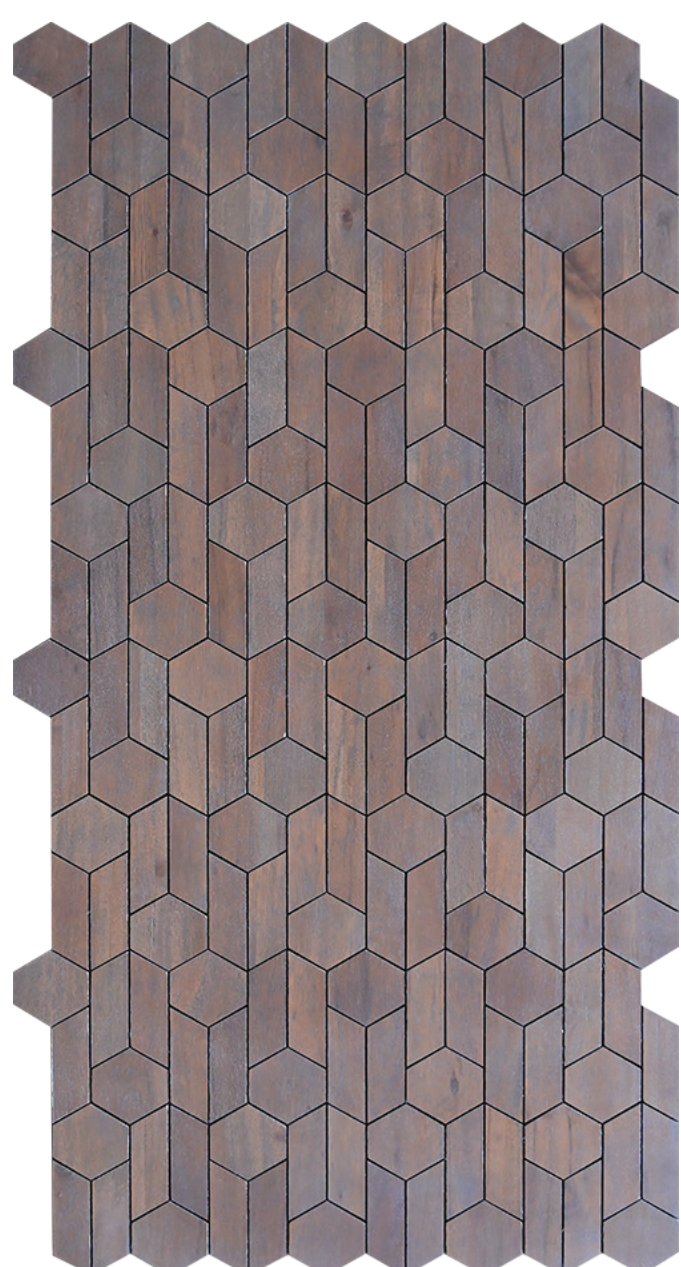

LLY 6.94



LLY 6.95



LLY 6.96

Hollmium Collection 2023



WALLS

Feature Wood Coverings

PEONY SERIES



Technical Details:-

Wood Veneer Specie	: INDIAN ACACIA
Wear Layer	: 0.5 mm
HDF Core	: HDHMR Grade
Wood Pieces Per Panel	: 256
Weight Per Panel	: 2.5 K.G.
Internal Groove Size	: 1.5 mm
Out-to-Out	: 1288.11 MM X 623.61 MM
In-to-In	: 1200.35 MM X 623.61 MM
Coverage in Sq. Ft	: 8 Sq. Ft. Per Panel
Thickness of Engineered Composite	: 4 mm
Backer	: Polyester Fabric
Finish	: Pre- Oiled

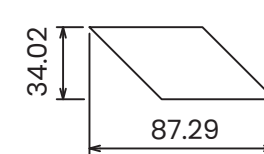
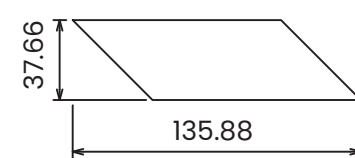
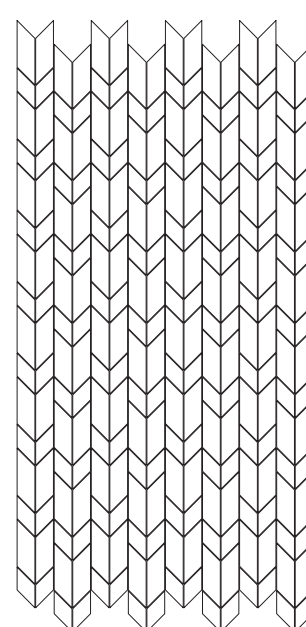

Scan

Hollmium Collection 2023



WALLS

Feature Wood Coverings

PEONY SERIES



PNY 6.91



PNY 6.92



PNY 6.93

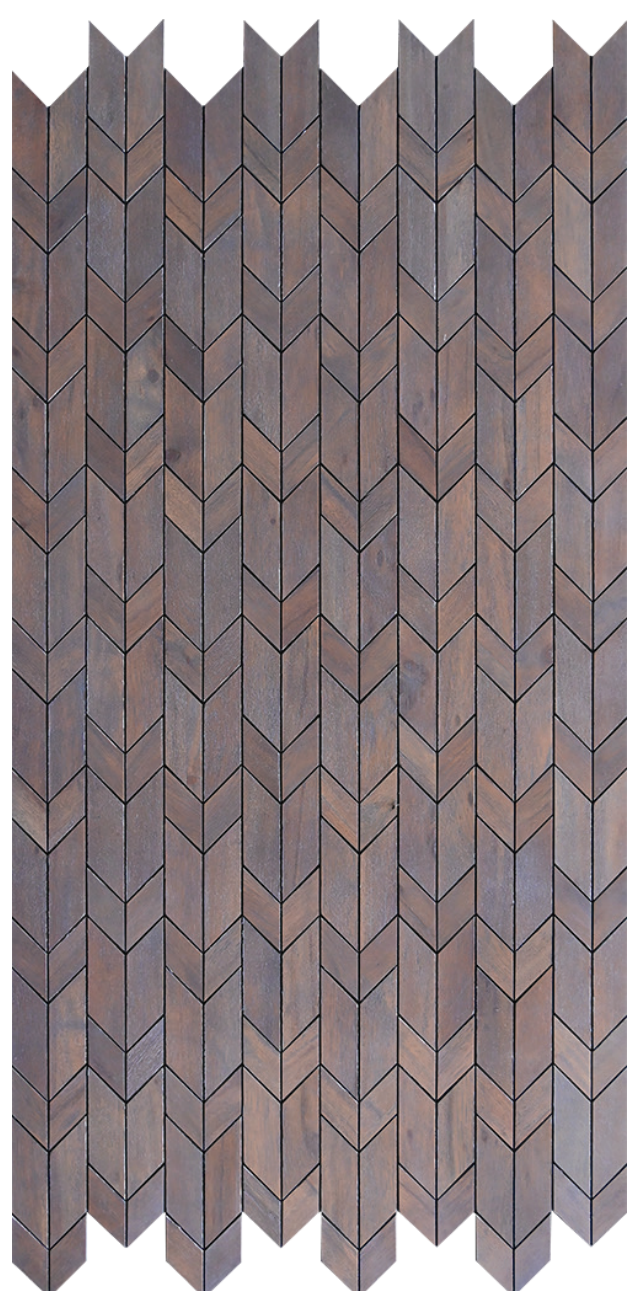

PNY 6.94



PNY 6.95



PNY 6.96

Hollmium Collection 2023



WALLS

Feature Wood Coverings

DIANTHUS SERIES



Technical Details:-

Wood Veneer Specie	: INDIAN ACACIA
Wear Layer	: 0.5 mm
HDF Core	: HDHMR Grade
Wood Pieces Per Panel	: 224
Weight Per Panel	: 2.5 K.G.
Internal Groove Size	: 1.5 mm
Out-to-Out	: 1287.32 MM X 628.60 MM
In-to-In	: 1188.70 MM X 628.60 MM
Coverage in Sq. Ft	: 8 Sq. Ft. Per Panel
Thickness of Engineered Composite	: 4 mm
Backer	: Polyester Fabric
Finish	: Pre- Oiled

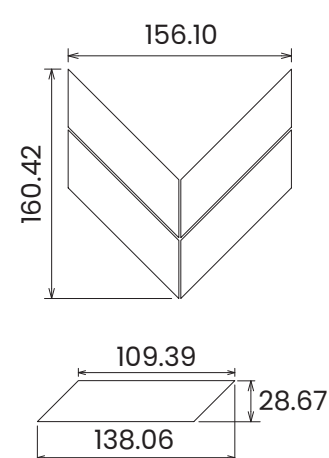
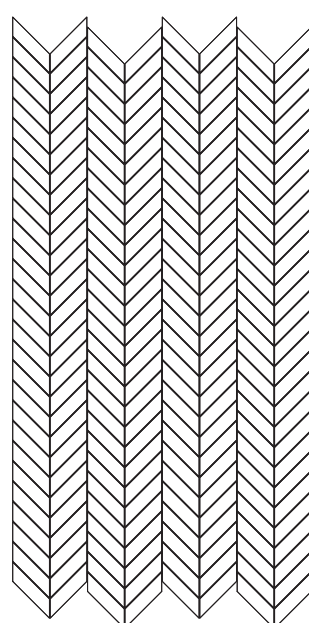

Scan

Hollmium Collection 2023



WALLS

Feature Wood Coverings

DIANTHUS SERIES

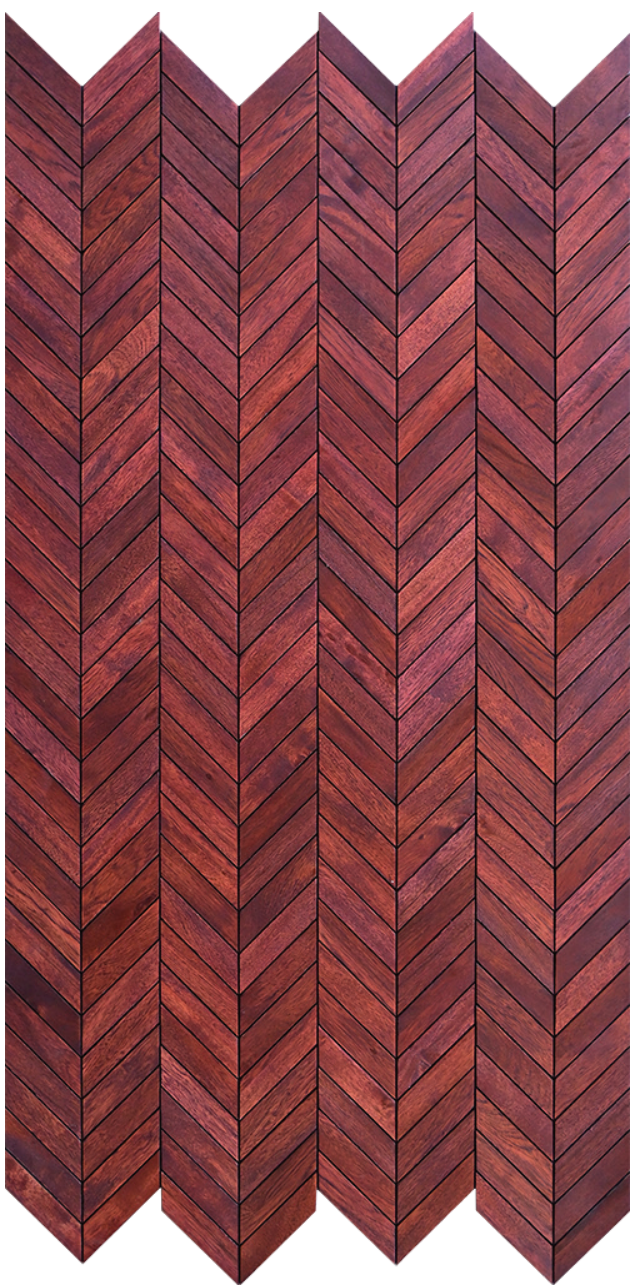

DNH 6.91

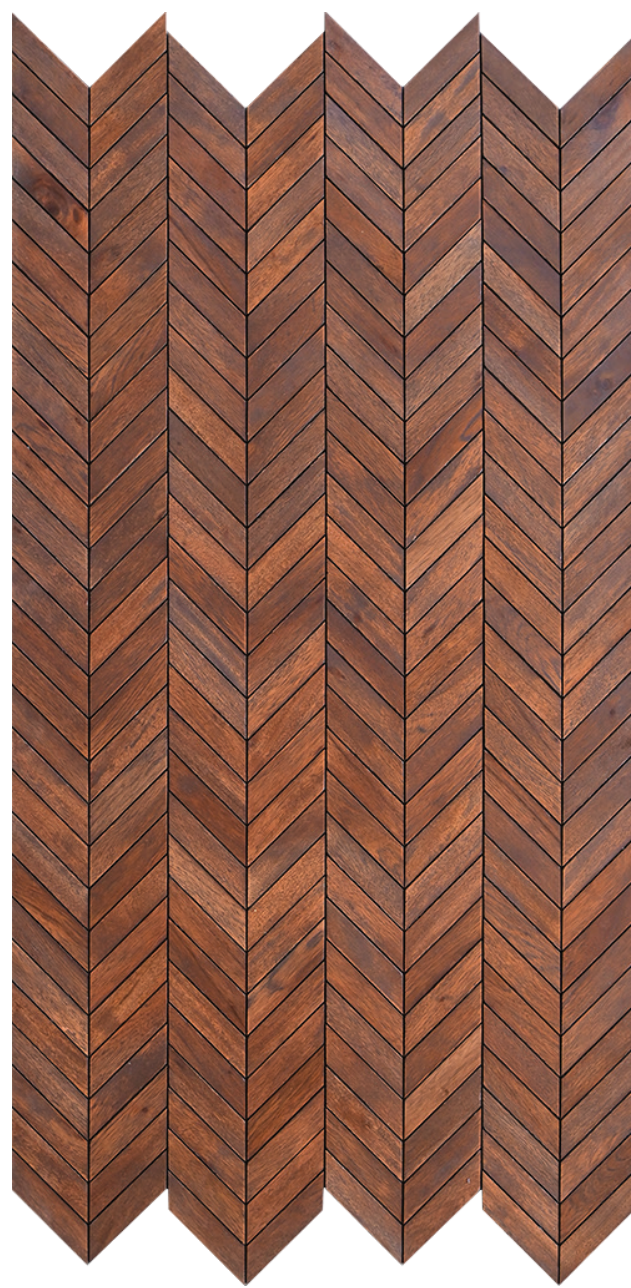

DNH 6.92



DNH 6.93

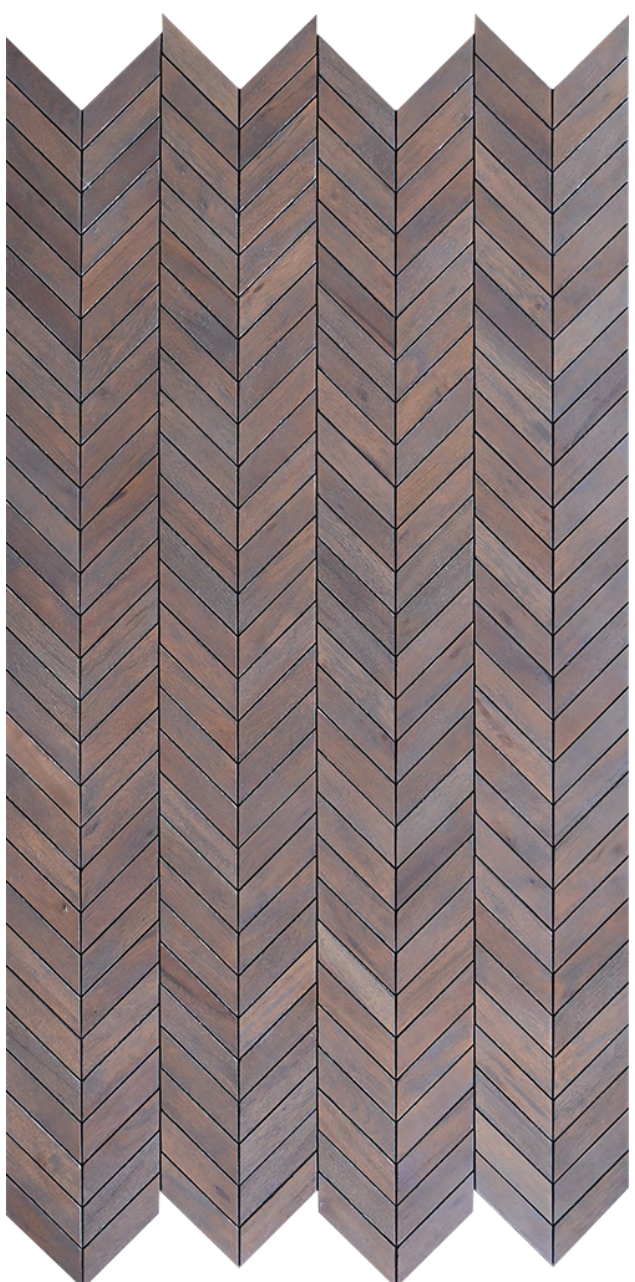

DNH 6.94

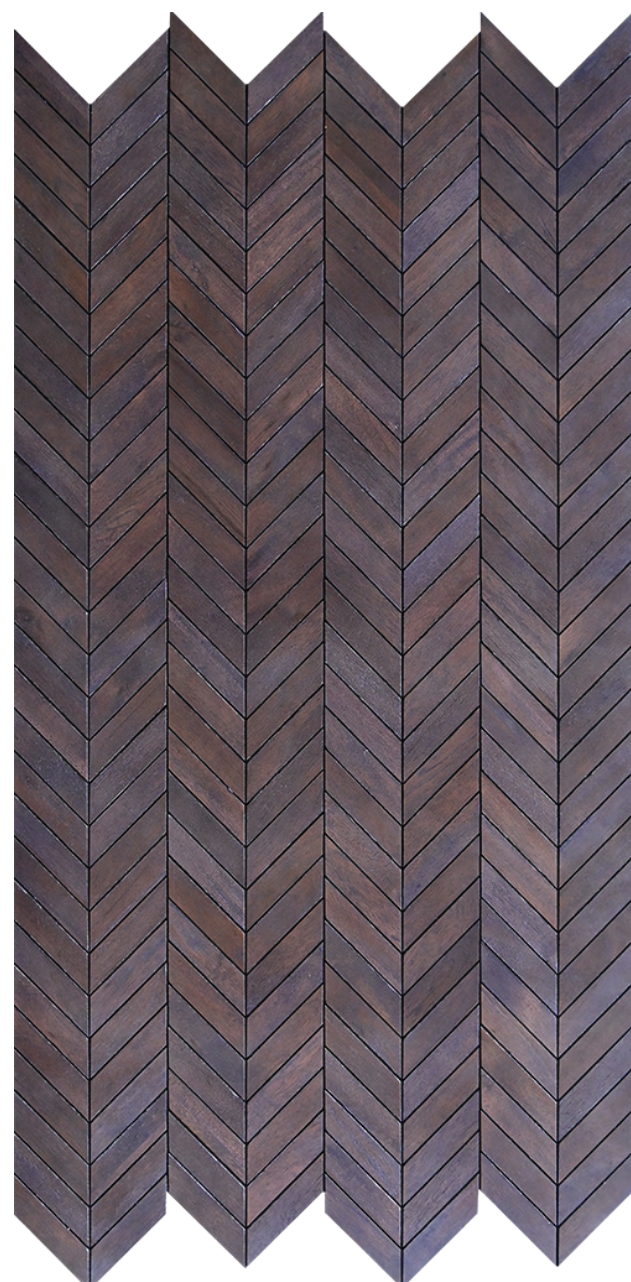

DNH 6.95



DNH 6.96

Hollmium Collection 2023



WALLS

Feature Wood Coverings

PRIMROSE SERIES



Technical Details:-

Wood Veneer Specie	: INDIAN ACACIA
Wear Layer	: 0.5 mm
HDF Core	: HDHMR Grade
Wood Pieces Per Panel	: 256
Weight Per Panel	: 2.5 K.G.
Internal Groove Size	: 1.5 mm
Out-to-Out	: 1260.67 MM X 611.40 MM
In-to-In	: 1224.03 MM X 611.40 MM
Coverage in Sq. Ft	: 8 Sq. Ft. Per Panel
Thickness of Engineered Composite	: 4 mm
Backer	: Polyester Fabric
Finish	: Pre- Oiled

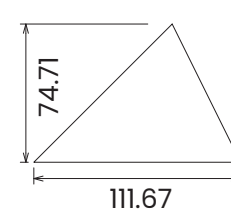
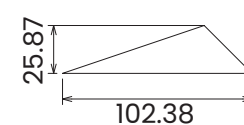
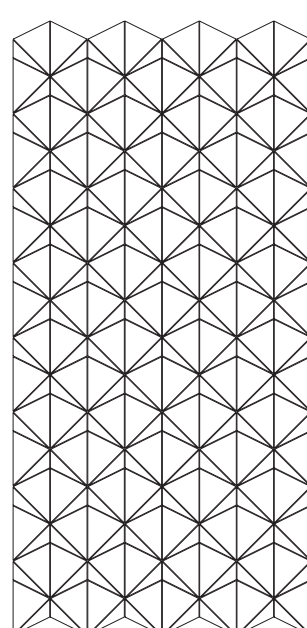

Scan

Hollmium Collection 2023



WALLS

Feature Wood Coverings

PRIMROSE SERIES

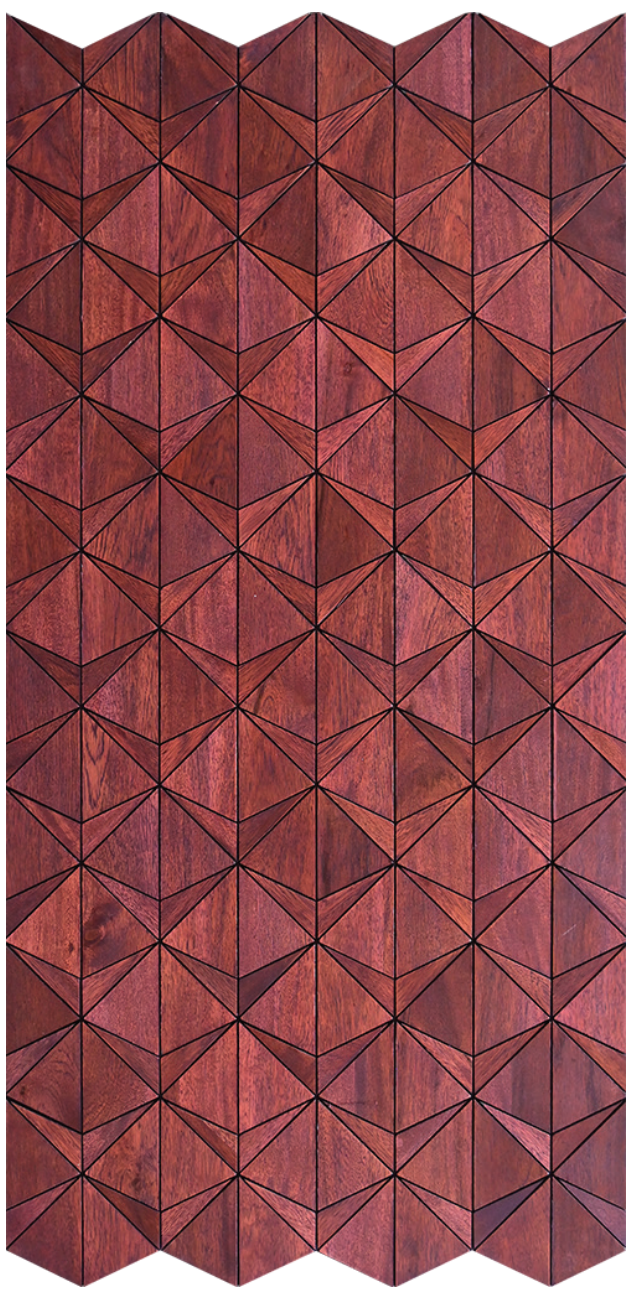

PMR 6.91



PMR 6.92



PMR 6.93



PMR 6.94



PMR 6.95



PMR 6.96

Hollmium Collection 2023



WALLS

Feature Wood Coverings

LOTUS SERIES



Technical Details:-

Wood Veneer Specie	: INDIAN ACACIA
Wear Layer	: 0.5 mm
HDF Core	: HDHMR Grade
Wood Pieces Per Panel	: 288
Weight Per Panel	: 2.5 K.G.
Internal Groove Size	: 1.5 mm
Out-to-Out	: 1275.27 MM X 611.40 MM
In-to-In	: 1224.20 MM X 611.40 MM
Coverage in Sq. Ft	: 8 Sq. Ft. Per Panel
Thickness of Engineered Composite	: 4 mm
Backer	: Polyester Fabric
Finish	: Pre- Oiled

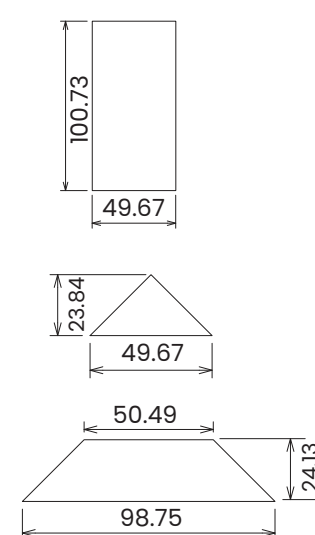
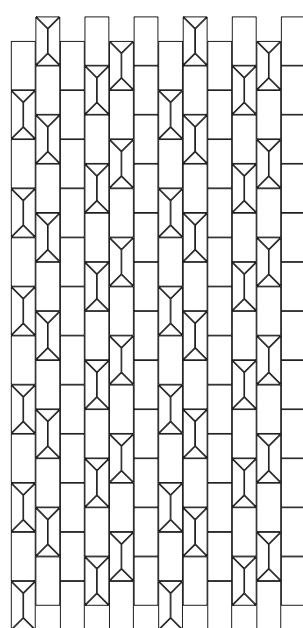

Scan

Hollmium Collection 2023



WALLS

Feature Wood Coverings

LOTUS SERIES

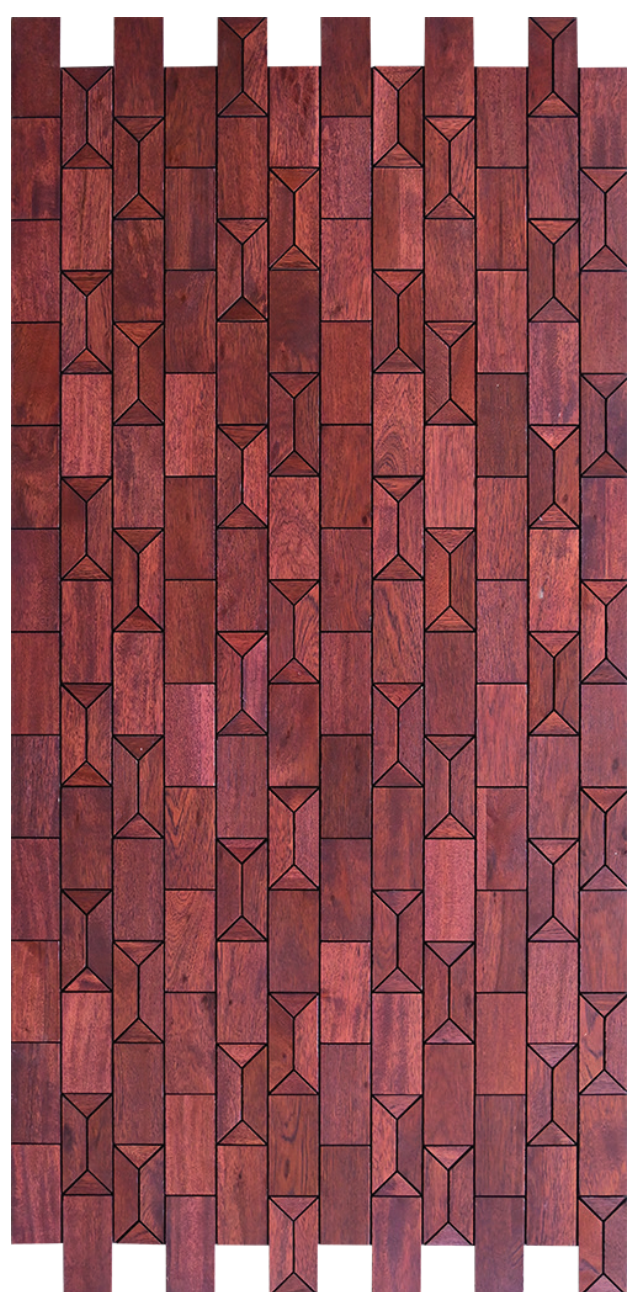

LTS 6.91

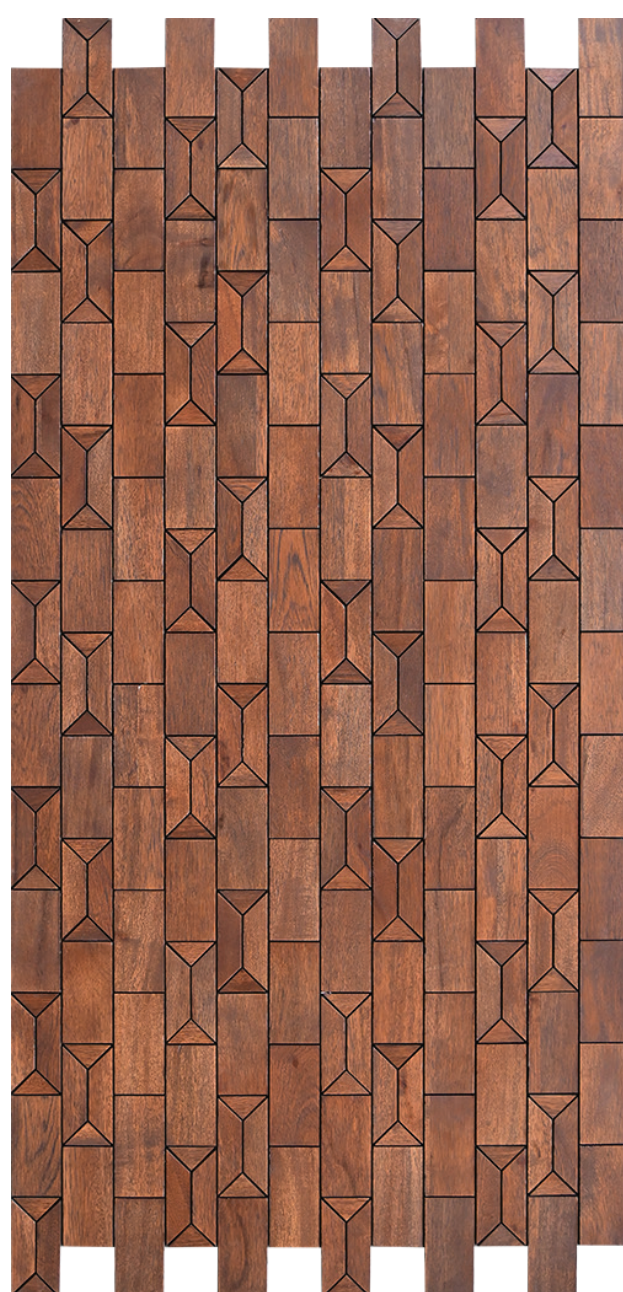

LTS 6.92



LTS 6.93

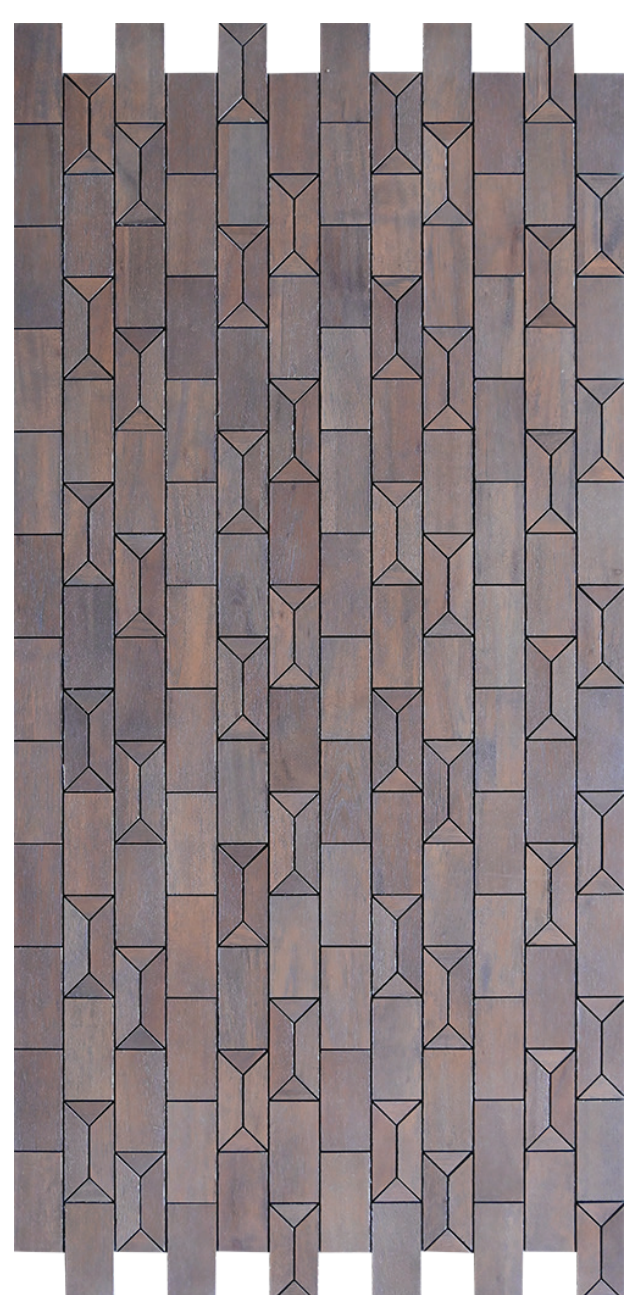

LTS 6.94



LTS 6.95

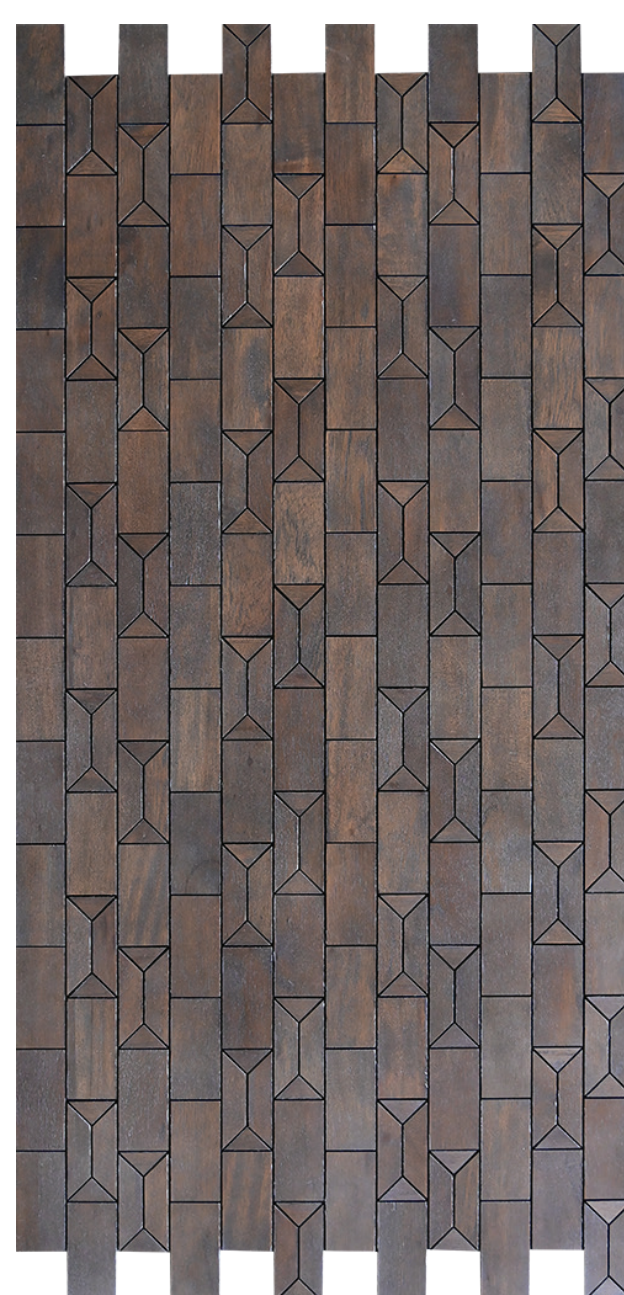

LTS 6.96

How to Apply ?

Please follow the application instructions for hassle free installation and maintenance-

1. Provide a completely dry and leveled surface for mounting "TD Walls" Panels. Liner materials such as 6 mm BWP plywood or 6 mm WPC sheets can be used for levelling purposes.
2. If "TD Walls" Panels are mounted directly onto walls (without liner material like plywood or WPC), ensure zero water seepage from the wall.
3. Applications in wet areas or excessively moist areas are not advisable.
4. Any standard glue (substrate to be considered) can be used for mounting "TD Walls" Panels. For standard installations on plywood surfaces standard PVAc white glues are recommended.
5. Always insist on using 2.5 mm spacers while laying out individual pieces next to each other.
6. Spacers should be used on all four sides to finalize placement before applying pressure mechanism to the surface.
7. Always insist on applying uniform pressure on surfaces when liquid white glues are used.
8. Maintain uniform pressure on the surface until the glue dries out completely. It is recommended to provide 6-8 hours curing time for the glue.
9. Please consider ability to apply uniform pressure in applications on curved surfaces.



Scan this code for how to apply "Wall" video

Care

1. Always clean with dry cloth.
2. Avoid cleaning with excessively wet or moist cloths.
3. Avoid highly acidic cleaning agents.
4. Water borne wood cleaning soaps can be used periodically for cleaning.
5. Avoid direct water contact or water logging for long duration on the wood surface.

'TD Walls' Panels installation procedure for wall claddings



Step-1: Provide a dry & levelled wall surface



Step-2: Apply liner material

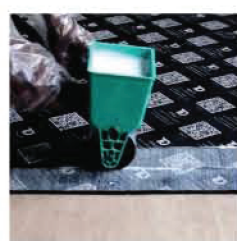

Step-3: Apply glue to product

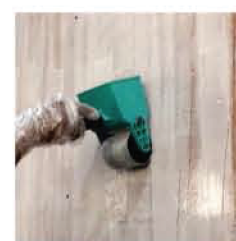

Step-4: Apply glue to liner material

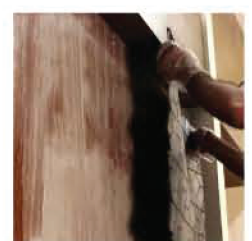

Step-5: Install panels



Step-6: Use spacers for interlocking panels



Step-7: Apply pressure mechanism

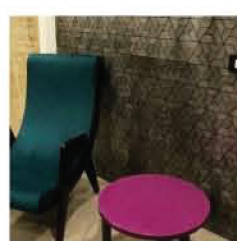

Step-8: Allow glue to dry & cure



Scan me

TURAKHIA DECOR LLP

 B - 904/905, Westgate, Nr. YMCA, Sarkhej - Gandhinagar Hwy, Makarba, Ahmedabad, Gujarat 380015

 Plot No: 1412, Nr. Jainson Cable, Chandarda Patiya, Village: Rajpur - 382715,
Tal: Kadi, Dist: Mehsana, Gujarat, India.

 /turakhiadecor

 /turakhiadecor

 /turakhiadecor

 /turakhiadecor

 /turakhiadecor

 /company/turakhiadecor

 +91 98703 87416

 info@turakhiadecor.com

 www.turakhiadecor.com